

## POWERLOGIC® Ethernet Gateway EGX100

### User's Guide

Instrucciones en Español: página 19

Instructions en Français: page 39

Anweisungen auf Deutsch: Seite 59

Retain for future use.

### TABLE OF CONTENTS



<b>INTRODUCTION</b> .....	<b>2</b>
Supported Ethernet Protocols .....	2
Hardware .....	2
Additional Resources .....	3
<b>ACCESSING THE EGX OVER A NETWORK</b> .....	<b>3</b>
Logging into the EGX .....	3
Logging Out .....	3
<b>EGX USER INTERFACE OVERVIEW</b> .....	<b>4</b>
<b>SETUP</b> .....	<b>5</b>
Ethernet and TCP/IP Settings .....	5
Duplicate IP Address Detection .....	6
Serial Port .....	7
Device List .....	8
Master Mode Device List Setup .....	8
Slave Mode Device List Setup .....	9
User Accounts .....	10
Web Page Access .....	11
Modbus TCP/IP Filtering .....	12
SNMP Parameters .....	13
<b>DIAGNOSTICS</b> .....	<b>14</b>
Statistics .....	14
Interpreting Statistics .....	15
Read Device Registers .....	17
<b>FIRMWARE</b> .....	<b>18</b>
Finding the Firmware Version .....	18
Getting New Firmware .....	18
Updating the Firmware File .....	18

## INTRODUCTION

This manual is to be used with a POWERLOGIC® EGX100 with firmware version 2.0 or higher. For installation information, see the installation manual.

The EGX100 is a communications device that provides connectivity between Ethernet (Modbus TCP/IP) and serial line devices, allowing Modbus TCP/IP clients to access information from serial slave devices. It also allows serial master devices to access information from serial slave devices distributed across an Ethernet network.

## Supported Ethernet Protocols

The EGX supports the following Ethernet protocols:

- **Modbus TCP/IP:** Modbus TCP/IP is a combination of the Modbus protocol, which provides master-slave communication between devices, and TCP/IP, which provides communications over an Ethernet connection. Modbus TCP/IP is used to exchange data between the EGX and other compatible Modbus TCP/IP devices via TCP port 502.
- **Hypertext Transfer Protocol (HTTP):** HTTP is a network protocol that handles the delivery of files and data on the World Wide Web. It provides web server functionality via TCP port 80. Remote configuration of the EGX and the viewing of diagnostic data is possible using a web browser.
- **File Transfer Protocol (FTP):** FTP is a network protocol that provides the ability to transfer files over the Internet from one computer to another. FTP is used to transfer firmware updates to the EGX via TCP port 21.
- **Simple Network Management Protocol (SNMP):** Based on MIB2 format, SNMP provides the ability to store and send identifying and diagnostic information used for network management purposes via UDP port 161 .
- **Address Resolution Protocol (ARP):** ARP is used to convert IP addresses to Ethernet addresses. ARP requests are sent by the EGX to determine if its address is a duplicate IP address (see “Duplicate IP Address Detection” on page 6).

## Hardware

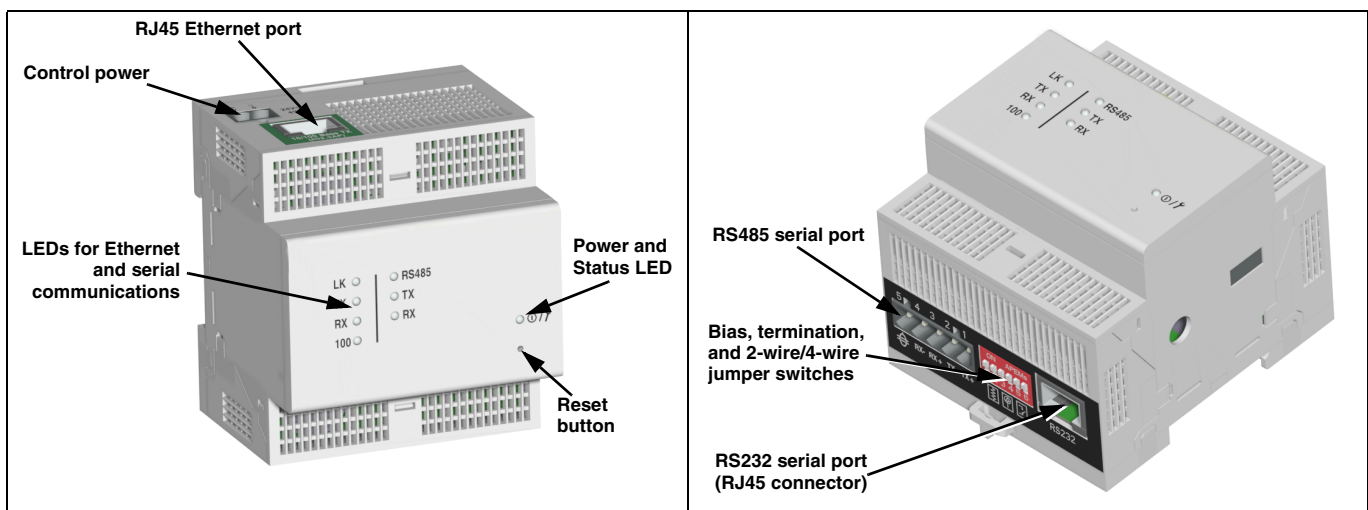

### Additional Resources

**Documentation:** Go to [www.powerlogic.com](http://www.powerlogic.com), select your country > literature > Communication Devices > Ethernet EGX > Instructional, and then click the manual you want to download.

**Firmware:** Go to [www.powerlogic.com](http://www.powerlogic.com), select your country > downloads > ECC/EGX Firmware, and then click the firmware file you want to download.

*NOTE: If you do not have a user name and password, follow the instructions on the web site.*

## ACCESSING THE EGX OVER A NETWORK

After you set up the Ethernet parameters (see the installation guide), you can access the EGX over an Ethernet LAN using Internet Explorer 6.0 or higher.

### Logging into the EGX

Action	Result
1. Launch Internet Explorer 6.0 or higher.	Opens Internet Explorer.
2. In the <b>Address</b> text box, type the address of your EGX (169.254.0.10 is the default), then press Enter.	Opens the Login dialog box.
3. Type your user name ( <i>Administrator</i> is the default) and password ( <i>Gateway</i> is the default) into the text boxes, then click <b>OK</b> .	Enters the user name and password, then opens the EGX home page.
4. Click <b>Setup</b> to access the EGX setup page, or click <b>Diagnostics</b> to access the EGX diagnostics page.	Opens the Setup or Diagnostics pages.

Figure 1: The EGX Home Page

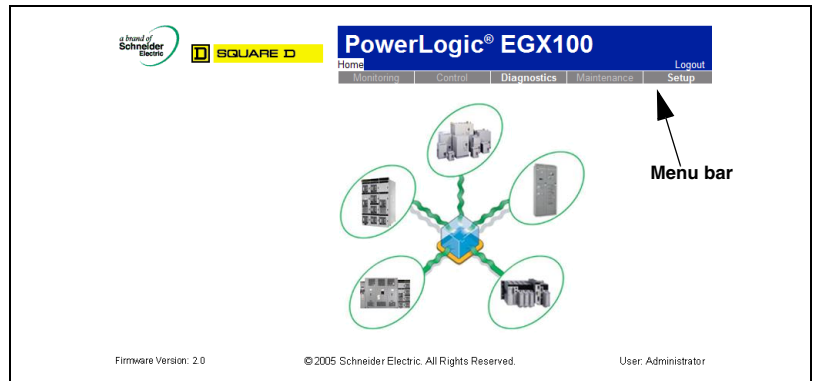

### Logging Out

We recommend logging out whenever you do not need access to the EGX.

To log out of the EGX configuration session, click **Log Out** to end your session.

## EGX USER INTERFACE OVERVIEW

The EGX ships with seven pre-installed web pages used for EGX setup and configuration. See Table 1 for a description of each web page.

**Table 1: EGX static web pages**

EGX Web Page	Description	See Page
<b>Setup</b>		
Ethernet & TCP/IP	Configure Ethernet and TCP/IP communication settings.	5
Serial Port	Set up or change serial communication parameters.	7
Device List	Identify serial devices on the daisy chain.	8
User Accounts <sup>①</sup>	Create and edit groups and users.	10
Web Page Access <sup>①</sup>	Select web page access rights for each user group.	11
Modbus TCP/IP Filtering <sup>①</sup>	Set up which IP addresses can access the EGX through Modbus TCP/IP.	12
SNMP Parameters <sup>①</sup>	Enable and configure the Simple Network Management Protocol (SNMP), which allows the EGX to identify itself to network devices requesting SNMP data.	13
<b>Diagnostics</b>		
Statistics	Displays diagnostic data used to troubleshoot network problems. This page also contains information about your specific EGX, including the serial number, manufacturing date, and Media Access Control (MAC) address.	14
Read Device Registers	Allows EGX administrators to read register data from a serial device connected to the EGX.	17

<sup>①</sup> Accessible by administrator only

## SETUP

To access the Setup web page links, click **Setup** on the **EGX menu bar**.

### Ethernet and TCP/IP Settings

Action	Result
1. From the Setup page, click <b>Ethernet &amp; TCP/IP</b> .	Opens the Ethernet & TCP/IP page.
2. Select your frame format and media type. Contact your network administrator if you do not know.	Selects the frame format and media type.
3. Enter your IP address, subnet mask, and default gateway address assigned to your EGX by your network administrator.	Enters the Ethernet parameters for the EGX. <i>NOTE: If you enter an IP address that is used by another device, you will be prompted to select a new IP address. See "Duplicate IP Address Detection" on page 6.</i>
4. Click <b>Apply</b> .	Updates the EGX Ethernet and TCP/IP settings.

\* See Table 2 on page 5 for a list of options.

*NOTE: After making changes to the Ethernet parameters and clicking Apply, the EGX will reboot.*

**Figure 2: Ethernet & TCP/IP Page**

**Table 2: EGX Ethernet and TCP/IP Settings**

Option	Description	Setting
Frame Format	Used to select the format for data sent over an Ethernet connection.	Ethernet II, 802.3 SNAP <b>Default:</b> Ethernet II
Media Type	Used to define the physical Ethernet connection or media type.	<ul style="list-style-type: none"> <li>• 10T/100Tx Auto</li> <li>• 10BaseT-HD</li> <li>• 10BaseT-FD</li> <li>• 100BaseTX-HD</li> <li>• 100BaseTX-FD</li> </ul> <b>Default:</b> 10T/100Tx Auto
IP Address	Used to enter the static IP address of the EGX.	0.0.0.0 to 255.255.255.255 <b>Default:</b> 169.254.0.10
Subnet Mask	Used to enter the Ethernet IP subnet mask address of your network.	0.0.0.0 to 255.255.255.255 <b>Default:</b> 255.255.0.0
Default Gateway	Used to enter the gateway (router) IP address used for wide area network (WAN) communications.	0.0.0.0 to 255.255.255.255 <b>Default:</b> 0.0.0.0

**Duplicate IP Address Detection**

While connected to your network, the EGX publishes its IP address. To avoid any duplicate IP address conflicts, the EGX uses the Address Resolution Protocol (ARP) to see if any other device on your network is using the same IP address. Table 3 below explains how the EGX handles a duplicate IP address when it is detected.

**Table 3: Duplicate IP Detection Scenarios**

Scenario	Duplicate IP Detected	Power/Status LED
Boot Process / Power Restore	Reverts to the default EGX IP address, subnet mask, and gateway address. ARP requests are sent every 15 seconds until the IP address is available. When the IP address becomes available, the EGX will use it.	Four blinks, pause pattern
Ethernet Link Detected		
Manual Address Change	EGX keeps it's previous IP address and displays a message indicating that the IP address is already in use by another device.	
Receives an ARP request	Reverts to the default EGX IP address, subnet mask, and gateway address if a connected device sends four ARP requests for the EGX's IP address. The EGX will send ARP requests every 15 seconds until the IP address is available again. When the IP address becomes available, the EGX will use it.	Four blinks, pause pattern

## Serial Port

Action	Result
1. From the Setup page, click <b>Serial Port</b> .	Opens the Serial Port page.
2. Select your mode, physical interface, transmission mode, baud rate, parity, and response timeout (see Table 4 on page 7).	Selects the serial port options.
3. If you select Slave mode, enter the IP addresses for the remotely connected devices (see Table 4 on page 7).	Enters the IP addresses of the remote devices.
4. Click <b>Apply</b> .	Updates the EGX Serial Port settings.

**Figure 3: Serial Port Page**

### Serial Port

Mode:	Master	▼
Physical Interface:	RS485 4-wire	▼
Transmission Mode:	Automatic	▼
Baud Rate:	19200	▼
Parity:	Even	▼
Response Timeout:	3	▼ (Seconds)

**Table 4: Serial Port Settings**

Option	Description	Setting
Mode	Used to select how the COM port on the EGX is utilized (master or slave). <i>NOTE: When the Mode is changed, the EGX reboots.</i>	Master, Slave <b>Default:</b> Master
Physical Interface	Used to select how the EGX serial port is physically wired.	RS485 4-wire, RS485 2-wire, or RS232 <b>Default:</b> RS485 2-wire
Transmission Mode	Used to select how data is transmitted over a serial connection.	<b>Master mode:</b> Automatic, Modbus ASCII <b>Slave mode:</b> Modbus RTU, Modbus ASCII <b>Default:</b> <ul style="list-style-type: none"> <li>• <b>Master mode:</b> Automatic</li> <li>• <b>Slave mode:</b> Modbus RTU</li> </ul> <i>NOTE: Automatic mode allows you to communicate to Modbus RTU, Jbus, and POWERLOGIC(SY/MAX) slave devices on the same daisy chain.</i>
Baud Rate	Used to select the data transmission speed over a serial connection.	2400, 4800, 9600, 19200, 38400, 56000*, 57600* <b>Default:</b> 19200
Parity	Used to select if data is checked for accuracy using a parity bit.	Even, None <b>Default:</b> Even
Response Timeout	Used to select how long the EGX will wait to receive a response from a serial device.	0.1 to 10 seconds <b>Default:</b> 3 seconds
Remote Modbus TCP/IP Connections (Slave mode only)	Used to define a list of Modbus TCP/IP addresses for the EGX to use during slave mode communications.	—

\* Available only if the physical interface and transmission mode is RS232/Modbus ASCII.

## Device List

Before you begin, keep in mind the following:

For master mode usage of the COM port:

- Modbus RTU/Jbus devices do not have to be defined in the Device List, but it helps you manage your system.
- POWERLOGIC protocol (SY/MAX) devices must be defined in the Device List.

*NOTE: Do not use serial slave addresses 1 or 16 in Automatic transmission mode on a daisy chain with mixed protocols (for example, a single daisy chain with some devices using POWERLOGIC protocol and others using Modbus RTU/Jbus protocol).*

### Master Mode Device List Setup

Figure 4: Master Mode Topology

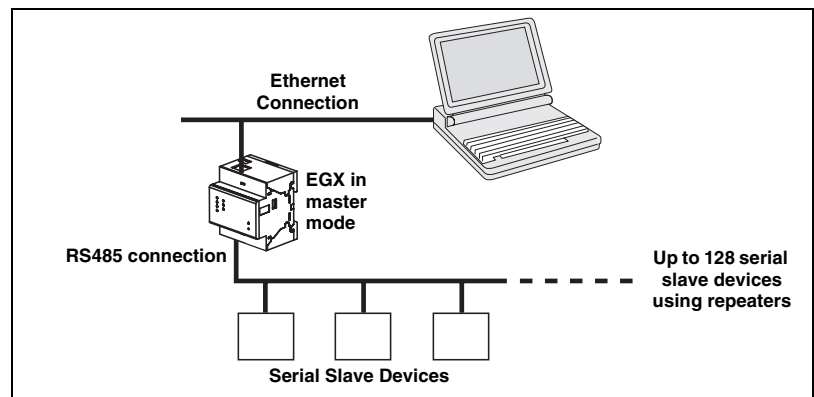

If you selected Master mode on the Serial Port page, follow the steps below to set up the device list:

Action	Result
1. From the Setup page, click <b>Device List</b> .	Opens the Device List page.
2. Select the number of viewable devices (1 to 128), then click <b>Apply</b> .	Selects the number of viewable locations that can be used to define serial slave devices connected to the EGX.
3. In the <b>Local ID</b> text box, type the local ID (address) of the serial slave device.	Enters the local address of the device.
4. Select the <b>Protocol</b> .	Selects the protocol of the connected device.
5. Repeat steps 3 and 4 until all of the devices are entered.	Enters all of the connected devices.
6. Click <b>Apply</b> .	Updates the Device List settings.

Figure 5: Device List Page in Master Mode

**Device List**

Number of Viewable Devices:

Local ID	Protocol
2	PowerLogic <input type="button" value="v"/>
3	Modbus <input type="button" value="v"/>
4	Jbus <input type="button" value="v"/>
5	Modbus <input type="button" value="v"/>
6	Modbus <input type="button" value="v"/>
7	Modbus <input type="button" value="v"/>
8	Modbus <input type="button" value="v"/>
9	Modbus <input type="button" value="v"/>



**Slave Mode Device List Setup**

Serial port slave mode allows serial Modbus master devices to access information from serial slave devices across a TCP/IP network. Figure 6 below illustrates how the devices are connected using the device list settings in Figure 7.

**Figure 6: Slave Mode Topology**

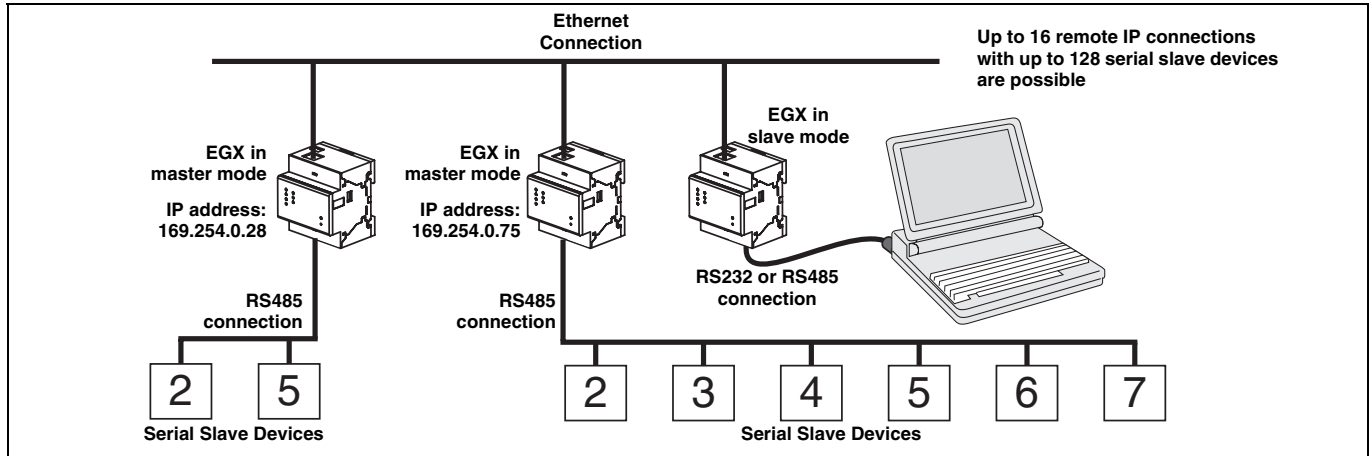

If you selected Slave mode on the Serial Port page, follow the steps below to set up the device list:

Action	Result
1. From the Setup page, click <b>Device List</b> .	Opens the Device List page.
2. Select the number of viewable devices (1 to 128), then click <b>Apply</b> .	Selects the number of viewable locations that can be used to define remote Modbus TCP/IP devices.
3. In the <b>Local ID</b> text box, type the local ID (address) of the serial slave device.	Enters the address of the device that the local Modbus master device will use to access the remote device.
4. In the <b>Remote ID</b> text box, type the remote ID (address) of the serial slave device.	Enters the serial slave address of the remotely connected device.
5. Select the <b>Connection</b> .	Selects the Modbus TCP/IP address to associate with the remote ID.
6. Repeat steps 3 through 5 until all of the devices are entered.	Enters all of the mapping information for the EGX to communicate to the remote devices.
7. Click <b>Apply</b> .	Updates the Device List settings.

**Figure 7: Device List Page in Slave Mode**

**Device List**

Number of Viewable Devices:  ▼

Local ID	Remote ID	Connection
1	2	169.254.0.28 ▼
2	5	169.254.0.28 ▼
3	2	169.254.0.75 ▼
4	3	169.254.0.75 ▼
5	4	169.254.0.75 ▼
6	5	169.254.0.75 ▼
7	6	169.254.0.75 ▼
8	7	169.254.0.75 ▼

## User Accounts

EGX users are assigned user names and passwords. Each user belongs to a group, and each group has access rights to the EGX Web pages assigned by the EGX administrator.

*NOTE: There are two default user accounts: Administrator (password is Gateway) and Guest (password is Guest).*

Action	Result
1. From the Setup page, click <b>User Accounts</b> .	Opens the User Accounts page.
2. If you want to change a group name, type a new name in one of the <b>Groups</b> text boxes (the Administrator group name cannot be changed).	Enters a new group name.
3. In the Users section, enter a Name (1 to 24 characters) and Password (0 to 12 characters) for a new user.  <i>NOTE: User names and passwords are case-sensitive and can contain only alphanumeric characters.</i>	Enters the name and password for a user.
4. Select a group and the default language for the new user.	Selects the group and language for a user.
5. Repeat steps 3 and 4 for each additional user you want to add.	Continues adding users.
6. Click <b>Apply</b> .	Saves all of the user account settings.

**Table 5: EGX accounts and passwords**

Account	Default Password
Administrator	Gateway
Guest	Guest
User-defined accounts (up to 11 accounts possible)	No default –Password is user-defined

**Figure 8: User Accounts Page**

The screenshot shows the 'User Accounts' configuration page. At the top, there is a 'Groups' section with four text input fields containing 'Administrators', 'Engineering', 'Operations', and 'Maintenance'. Below this is the 'Users' section, which is a table with four columns: 'Name', 'Password', 'Group', and 'Language'. The first row is pre-filled with 'Administrator', a masked password '\*\*\*\*\*', 'Administrators' (selected in a dropdown), and 'English' (selected in a dropdown). There are 10 empty rows for adding new users. The last row is pre-filled with 'Guest', a masked password '\*\*\*\*\*', 'Guest' (selected in a dropdown), and 'English' (selected in a dropdown). At the bottom of the page is an 'Apply' button.

## Web Page Access

Action	Result
1. From the Setup page, click <b>Web Page Access</b> .	Opens the Web Page Access page.
2. In the <b>Ethernet &amp; TCP/IP</b> row, select the access level (None, Read-only, or Full) that each user group will have for the Ethernet & TCP/IP web page.	See Table 6 below for an explanation of access levels for each group.
3. To allow Guest access to the web page, select <b>Read-only</b> under the <b>Guest</b> column. <i>NOTE: If the Guest group is Read-only, other groups may only be set to Read-only or Full.</i>	Allows the default Guest group to access the web page.
4. Repeat steps 2 and 3 for the Serial Port, Device List, Statistics, and Read Device Registers rows.	Selects the access level for each web page.
5. Click <b>Apply</b> .	Saves the password settings.

**Table 6: Group Access**

Group	Access
Administrator	Full access to all web pages <i>NOTE: We recommend that you change the default administrator password for system security the first time you log in.</i>
Guest	Read-only access to selected web pages.
Three user-defined groups	Choosing from the following options, the administrator assigns web page access for each group. Access levels are as follows: <ul style="list-style-type: none"> <li>• <b>None</b>: a group has no access to selected web page</li> <li>• <b>Read-only</b>: password grants a group read-only access to the selected web page</li> <li>• <b>Full</b>: a group has the same access as the Administrator group to the selected web page</li> </ul>

**Figure 9: Web Page Access Page**

### Web Page Access

	Engineering	Operations	Maintenance	Guest
Ethernet & TCP/IP	Read-only ▼	Read-only ▼	Read-only ▼	None ▼
Serial Port	Read-only ▼	Read-only ▼	Read-only ▼	None ▼
Device List	Read-only ▼	Read-only ▼	Read-only ▼	None ▼
Statistics	Read-only ▼	Read-only ▼	Read-only ▼	None ▼
Read Device Registers	Read-only ▼	Read-only ▼	Read-only ▼	None ▼

## Modbus TCP/IP Filtering

This function allows the administrator to specify Modbus TCP/IP client devices that have or do not have access to serial slave devices connected to the EGX.

*NOTE: There is an anonymous Modbus TCP/IP address (\*\*\*.\*\*\*.\*\*\*.\*\*\*) that can be set to Read-only or None. Setting it to **Read-only** allows any Modbus TCP/IP client not in the filtered list to access serial slave devices with read-only access. Setting it to **None** blocks all Modbus TCP/IP clients not in the filtered list.*

Action	Result
1. From the Setup page, click <b>Modbus TCP/IP Filtering</b> .	Opens the Modbus TCP/IP Filtering page.
2. Check <b>Enable Filtering</b> .	Activates filtering.
3. In the <b>IP address</b> column, enter the Modbus TCP/IP client address	Enters an IP address for a Modbus TCP/IP client that will have access to the serial devices connected to the EGX.
4. In the <b>Access Level</b> column, select Read-only or Full.	Selects the access level for the corresponding IP address. When set to Read-only, only the following Modbus TCP/IP function codes are allowed: <b>Decimal:</b> 1, 2, 3, 4, 7, 8, 11, 12, 17, 20, 24, 43, 100 <b>Hexadecimal:</b> 01, 02, 03, 04, 07, 08, 0B, 0C, 11, 14, 18, 2B, 64
5. Repeat steps 3 and 4 to add more IP addresses.	Continues adding IP addresses for filtering.
6. Click <b>Apply</b> .	Saves the Modbus TCP/IP address filtering list.

Figure 10: Modbus TCP/IP Filtering Page

**Modbus TCP/IP Filtering**

Enable Filtering:

IP Address				Access Level
***	***	***	***	Read-only ▼
169	254	0	33	Full ▼
				Read-only ▼
				Read-only ▼
				Read-only ▼
				Read-only ▼
				Read-only ▼
				Read-only ▼
				Read-only ▼
				Read-only ▼
				Read-only ▼

## SNMP Parameters

The EGX supports SNMP, allowing a network administrator to remotely access an EGX with an SNMP manager and view the networking status and diagnostics in the MIB2 format.

Action	Result
1. From the Setup page, click <b>SNMP Parameters</b> .	Opens the SNMP Parameters page.
2. Check <b>Enable SNMP</b> to turn ON the simple network management protocol. <i>NOTE: If you uncheck Enable SNMP and click Apply, the EGX will reboot and SNMP functionality will be turned OFF.</i>	Activates SNMP.
3. Enter the system contact, system name, system location, read-only community name, and the read-write community name.	Enters the SNMP system information and community access names.
4. Click <b>Apply</b> .	Saves the SNMP settings.

Figure 11: SNMP Parameters Page

**SNMP Parameters**

---

Enable SNMP:

System Contact:

System Name:

System Location:

Read-only Community Name:

Read-write Community Name:

## DIAGNOSTICS

To access the Diagnostics web page links, click **Diagnostics** on the **EGX** menu bar.

### Statistics

Action	Result
1. From the Diagnostics page, click <b>Statistics</b> .	Opens the Statistics page (see Figure 12). <i>NOTE: The Statistics page displays data based on the mode selected in "Serial Port" on page 7.</i>
2. View the data.	See "Interpreting Statistics" below.
3. Click <b>Reset</b> .	Resets the EGX cumulative diagnostic data to 0.

*NOTE: This page will show accumulated readings since the EGX was last activated. If power to the EGX is lost, all cumulative values reset to zero.*

Figure 12: Statistics Page

Reading with Serial Port in MASTER MODE	Reading with Serial Port in SLAVE MODE
<b>Statistics</b>	<b>Statistics</b>
<b>Ethernet</b>	<b>Ethernet</b>
Link Status: 100BaseTx-FD	Link Status: 100BaseTx-FD
Frames Transmitted OK: 375	Frames Transmitted OK: 2077256
Collisions: 0	Collisions: 0
Excessive Collisions: 0	Excessive Collisions: 0
Frames Received OK: 430	Frames Received OK: 2027312
CRC Errors: 0	CRC Errors: 0
Alignment Errors: 0	Alignment Errors: 0
Frames Too Long: 0	Frames Too Long: 0
Frames Too Short: 0	Frames Too Short: 21
<b>Modbus TCP/IP</b>	<b>Modbus TCP/IP</b>
Frames Sent: 0	Frames Sent: 1976313
Frames Received: 0	Frames Received: 1976309
Protocol Errors: 0	Protocol Errors: 0
Active Connections: 0	Outbound Read Messages: 157829
Accumulative Connections: 0	Outbound Write Messages: 0
Maximum Connections: 0	Inbound Reply Messages: 157825
Inbound Read Messages: 0	<b>Serial Port</b>
Inbound Write Messages: 0	Frames Sent: 222353
Outbound Reply Messages: 0	Frames Received: 222357
<b>Serial Port</b>	CRC Errors: 0
Frames Sent: 0	Protocol Errors: 0
Frames Received: 0	Inbound Read Messages: 222357
CRC Errors: 0	Inbound Write Messages: 0
Protocol Errors: 0	<b>Gateway Information</b>
Timeouts: 0	Firmware Version: 2.000
Outbound Read Messages: 0	System Idle Time: 43%
Outbound Write Messages: 0	MAC Address: 00:80:67:80:35:5A
<b>Gateway Information</b>	Serial Number: 33000001
Firmware Version: 2.000	Model Number: EGX100SQD
System Idle Time: 43%	Hardware Version: A1
MAC Address: 00:80:67:80:35:5A	Manufacture Date: 2005-Jan-01
Serial Number: 33000001	<input type="button" value="Reset"/>
Model Number: EGX100SQD	
Hardware Version: A1	
Manufacture Date: 2005-Jan-01	
<input type="button" value="Reset"/>	

Interpreting Statistics

Statistic	Description
<b>Ethernet</b>	
Link Status	A status string that represents the speed and duplex setting being used to communicate with the linking partner.
Frames Transmitted OK	A counter that increments each time a frame is successfully transmitted.
Collisions	A counter that increments each time a frame is retransmitted due to collision detection.
Excessive Collisions	A counter that increments each time a frame is not able to be sent due to reaching the maximum collision status based on the Truncated Binary Exponential Backoff algorithm.
Frames Received OK	A counter that increments each time a frame is successfully received.
CRC Errors	A counter that increments each time a frame is received that has a checksum/CRC that does not match what is calculated.
Alignment Errors	A counter that increments each time a frame is received that has a checksum/CRC error and does not end on an 8-bit frame boundary.
Frames Too Long	A counter that increments each time a frame is received that is larger than the allowed maximum size defined in the standards (frames larger than 1518 bytes).
Frames Too Short	A counter that increments each time a frame is received that is smaller than the allowed minimum size defined in the standards (frames smaller than 64 bytes).
<b>Modbus TCP/IP</b>	
Frames Sent	A counter that increments each time a frame is sent.
Frames Received	A counter that increments each time a frame is received.
Protocol Errors	A counter that increments each time an ill-formed message is received.
Active Connections <sup>①</sup>	A status value that represents the number of connections that are active at the moment the diagnostics page is refreshed. A maximum of 32 connections are supported. Clicking Active Connections opens a new window with a list of all of the active client connections.
Accumulative Connections <sup>①</sup>	A counter that increments each time a connection is made to the EGX.
Maximum Connections <sup>①</sup>	A status value that represents the maximum number of connections that were active at any given moment.
Inbound Read Messages <sup>①</sup>	A counter that increments each time a read request message is received.
Outbound Read Messages <sup>②</sup>	A counter that increments each time a read request message is sent.
Inbound Write Messages <sup>①</sup>	A counter that increments each time a write request message is received.
Outbound Write Messages <sup>②</sup>	A counter that increments each time a write request message is sent.
Inbound Reply Messages <sup>②</sup>	A counter that increments each time a reply message is received.
Outbound Reply Messages <sup>①</sup>	A counter that increments each time a reply message is sent.

<sup>①</sup> Available when the serial port is in Master mode.

<sup>②</sup> Available when the serial port is in Slave mode

Statistic	Description
<b>Serial Port</b>	
Frames Sent	A counter that increments each time a frame is sent.
Frames Received	A counter that increments each time a frame is received.
CRC Errors	A counter that increments each time a message is received that has a CRC that does not match what is calculated. Typically the result of wiring issues.
Protocol Errors	A counter that increments each time an ill-formed message is received.
Timeouts	A counter that increments each time a request message is sent without receiving a corresponding response message within the allowed time. Timeouts are typically the result of configuration errors or a non-responsive device.
Inbound Read Messages <sup>②</sup>	A counter that increments each time a read request message is received.
Outbound Read Messages <sup>①</sup>	A counter that increments each time a read request message is sent.
Inbound Write Messages <sup>②</sup>	A counter that increments each time a write request message is received.
Outbound Write Messages <sup>①</sup>	A counter that increments each time a write request message is sent.
<b>Gateway Information</b>	
Firmware Version	The firmware version that is installed on the EGX.
System Idle Time	A percentage from 0% to 100% indicating the average processor time that is not being used.
MAC Address	The unique Ethernet hardware address of an EGX.
Serial Number	The serial number of the EGX.
Model Number	The EGX model number (100).
Hardware Version	EGX hardware version.
Manufacture Date	Date the EGX was manufactured.

<sup>①</sup> Available when the serial port is in Master mode.

<sup>②</sup> Available when the serial port is in Slave mode



## Read Device Registers

Action	Result
1. From the Diagnostics page, click <b>Read Device Registers</b> .	Opens the Read Device Registers page.
2. Enter the device ID, starting register number, and the number of registers to read.	Enters the values to begin reading registers for the specified device.
3. Click <b>Read Holding Registers</b> or <b>Read Input Registers</b> .	Displays the values for the listed registers.
4. To change how the data is displayed in the Value column, select <b>Decimal</b> , <b>Hexadecimal</b> , <b>Binary</b> , or <b>ASCII</b> .	Selects how the data values are displayed.

**Table 7: EGX Read Device Register Settings**

Option	Description	Default
Device ID	The address of the device that registers are read.	1
Starting Register	The first register to read.	1000
Number of Registers	The number of registers to read (1 to 10).	10
Register column	Lists the register numbers	—
Value column	Lists the data stored in a register.	—
Decimal, Hexadecimal, Binary, or ASCII options	Select an option to specify how the Value column data is displayed.	Decimal

**Figure 13: Read Device Registers Page**

### Read Device Registers

Device ID:       Starting Register:       Number Of Registers:

Register	Value	
1000	0	<input type="button" value="Read Holding Registers"/>
1001	0	<input type="button" value="Read Input Registers"/>
1002	0	<input checked="" type="radio"/> Decimal
1003	0	<input type="radio"/> Hexadecimal
1004	0	<input type="radio"/> Binary
1005	0	<input type="radio"/> ASCII
1006	0	
1007	0	
1008	0	
1009	0	

## FIRMWARE

Firmware on the EGX can be updated using File Transfer Protocol (FTP). Check [www.powerlogic.com](http://www.powerlogic.com) or with your local sales representative for the latest firmware update.

### Finding the Firmware Version

Action	Result
1. Log into the EGX.	Opens the EGX home page.
2. Locate the firmware version on the bottom-left corner of the page.  <i>NOTE: If you recently updated your firmware, press F5 to refresh the web page and update the displayed firmware number.</i>	Determines the firmware version of the EGX.
3. Alternatively, you can select <b>Diagnostics &gt; Statistics</b> to find the firmware version in the Gateway Information section.	Also determines the firmware version of the EGX.

### Getting New Firmware

Action	Result
1. Launch Internet Explorer, type <a href="http://www.powerlogic.com">www.powerlogic.com</a> in the <b>Address</b> text box, then press Enter.	Opens the POWERLOGIC web site.
2. Click <b>downloads</b> .	Opens the downloads page.
3. Enter your user name and password, then click <b>LogIn</b> .	Logs into the <b>Technical Support</b> page.
4. Click the <b>ECC/EGX Firmware</b> link.	Opens the ECC/EGX Firmware page.
5. Click the firmware file link (eg####.bin, where #### is the firmware number), then click <b>Save</b> .	Opens the File Download dialog box, then saves the firmware file.

### Updating the Firmware File

Action	Result
1. Launch Internet Explorer, type <i>ftp://</i> and the IP address of the EGX in the Address text box (for example, <i>ftp://169.254.0.10</i> ), then press Enter.	Opens the <b>Log On As</b> dialog box.
2. Type the user name <i>Administrator</i> and the administrator password in the text boxes, then click <b>Log On</b> .	Opens an FTP session with the EGX.
3. Locate the saved firmware file on your computer, select it, then press CTRL+C.	Copies the firmware file to the clipboard.
4. Right-click in the Internet Explorer window, then click <b>Paste</b> .  <i>NOTE: Instead of copying and pasting the firmware file, you can drag-and-drop the firmware file into Internet Explorer.</i>	Copies the firmware to the EGX, and the EGX reboots.
5. Click the <b>Close</b> button on the Internet Explorer window.	Closes Internet Explorer and ends the FTP connection to the EGX.
6. To verify that the firmware version was updated successfully, follow the steps in "Finding the Firmware Version" on page 18.	Verifies the updated firmware version.